

Block 2 - My Redwork Garden

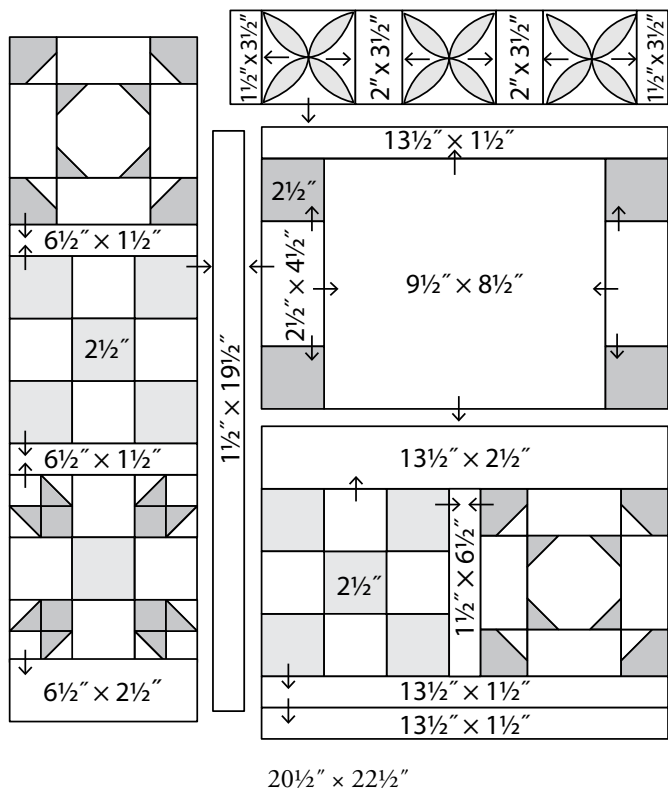

Measurements are unfinished sizes.

Use 1/4" seams. Press in direction of arrows.

Pay attention to the directional print of the fabrics.

All directional fabrics are marked with (*).

Refer to color photo.

BLOCK CUTTING INSTRUCTIONS: CONT'D

Honey Bee Fleur Block

Honey Bee Cream-Red:*

- (1) 2 1/2" x 2 1/2" fussy-cut for center square

Lily Days Red:

- (4) 2 1/4" x 2 1/4" for HSTs
- (4) 1 1/2" x 1 1/2" for Four-Patch corners

Cobblestone Cream:

- (4) 2 1/2" x 2 1/2" for Nine-Patch squares
- (4) 2 1/4" x 2 1/4" for HSTs
- (4) 1 1/2" x 1 1/2" for Four-Patch corners

Block Borders & Sashing

Early Birds Cream-Red:* (1) 13 1/2" x 1 1/2" for border

Cobblestone Cream-Red:

- (3) 6 1/2" x 1 1/2" for sashing
- (1) 6 1/2" x 2 1/2" for border

Morning Glories Stripe Cream-Red:*

- (1) 1 1/2" x 19 1/2" for vertical sashing
- (1) 13 1/2" x 2 1/2" for sashing
- (1) 13 1/2" x 1 1/2" for border

BLOCK CONSTRUCTION:

Nine-Patch Blocks

- Gather 5 Flirty Fleurs Cream-Red squares 2 1/2" and 4 squares 2 1/2" of Berry Dots Cream. Lay the squares into a Nine-Patch configuration of 3 rows of 3 squares as shown.

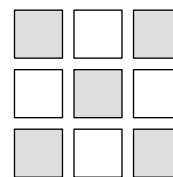

- Sew the squares together by row. Sew rows together, nesting seams as you go.
- Repeat to make a second Nine-Patch using 5 Lily Days Cream-Red with 4 Berry Dots Cream squares.

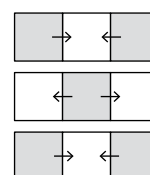

BLOCK CUTTING INSTRUCTIONS:

Embroidery Block

Cobblestone Cream:

- (1) 10" x 9" for embroidery background, oversized
- Honey Bee Cream-Red:* (2) 2 1/2" x 4 1/2" for side borders
- Morning Glories Stripe Red:* (2) 2 1/2" x 2 1/2" for corners
- Lily Days Red: (2) 2 1/2" x 2 1/2" for corners

Petal Blocks

Lily Days Cream: (3) 3 1/2" x 3 1/2" for backgrounds

Early Birds Cream-Red:

- (2) 2" x 3 1/2" for sashing
- (2) 1 1/2" x 3 1/2" for sashing

Cobblestone Cream-Red:

- (1) 13 1/2" x 1 1/2" for sashing

Nine-Patch Blocks (2)

Lily Days Cream-Red: (5) 2 1/2" x 2 1/2"

Flirty Fleurs Cream-Red: (5) 2 1/2" x 2 1/2"

Berry Dots Cream: (8) 2 1/2" x 2 1/2"

Ring Around A Robin Blocks (2)

Cobblestone Red: (8) 2" x 2" for outer corners

Flirty Fleurs Red: (8) 1 1/2" x 1 1/2" for inside corners

Early Birds Cream-Red:* (2) 3 1/2" x 3 1/2" snowball centers

Dandelions Cream:

- (8) 2" x 3 1/2" for sides, top & bottom
- (8) 1 1/2" x 1 1/2" for snowball corners

Block 2 cont'd - My Redwork Garden

Ring Around A Robin Blocks

Stitch-and-Flip method

- Snowball each corner of 2 Early Birds Cream-Red 3½" squares with 8 Flirty Fleurs Red 1½" squares using the stitch-and-flip method.
- Draw a diagonal line on the wrong side of small square.
- Match small square to a corner of a large square to be snowballed, right sides together. Drawn line must touch 2 sides of the large square.
- Stitch on drawn line. Trim excess. Flip small square open to the right side: 1 corner snowballed à la stitch and flip method. Repeat for all corners.



- Use the stitch and flip method to snowball only one corner of 8 Cobblestone Red 2" squares using 8 Dandelion Cream 1½" squares.



- Following diagram and color photo, arrange block elements into a Nine-Patch formation.
- Sew Ring Around A Robin blocks together as shown.

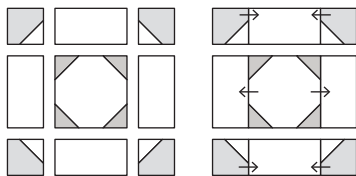

Honey Bee Fleur Block

Half-Square Triangles

- For the Honey Fleur Block pair 4 Cobblestone Cream 2¼" squares with 4 Lily Days Red 2¼" squares to make 8 HSTs. Follow the technique described in Block 1, Buttercup Trio Unit Instructions, page 6. Trim to 1½" square.

Lily Corner Petals

- Create a Four-Patch with 2 HSTs, 1 Lily Days Red, and 1 Dandelions Cream 1½" squares. Pay attention to the orientation of the HSTs.
- Sew the top row units together, then the bottom row.
- Join the 2 rows. Repeat to make 4 Lily Corner Petals.

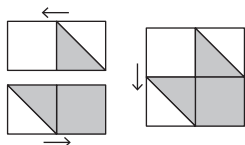

Honey Bee Fleur Block Assembly

- Gather center 2½" Honey Bee square, 4 Corner Petals and 4 Cobblestone Cream 2½" squares.
- Arrange block elements into a Nine-Patch formation as shown.
- Sew the Honey Bee Fleur Block together by row, then sew rows together.

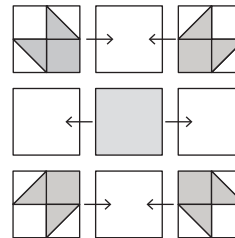

APPLIQUÉ DIRECTIONS:

Petal Blocks:

- Using your favorite method of appliqué, prepare 12 petals, following color photo. Appliqué to Lily Days Cream 3½" square background blocks.



EMBROIDERY BACKGROUND:

- Use the oversized rectangle 10" x 9" for the embroidery background; it will be trimmed to 9½" x 8½" after embroidery is complete.
- Optional Pellon Interfacing: I used a lightweight Pellon fusible interfacing to add stability to the embroidery and help hide thread ends. It's lightweight and goes into the seam allowance without adding bulk.
- Cut a Pellon rectangle 10" x 9". Iron the interfacing to the back of the background following manufacturer's instructions. You'll be able to see through it to trace the drawings.
- Place background over pattern and trace drawing. Complete embroidery and trim block to 9½" x 8½".

EMBROIDERY: USE 2 STRANDS FLOSS

A tiny stem stitch or backstitch is used for all of the embroidery with the exception of the following:

- **Flower Buds & Mouse Eyes:** Outline with a tiny backstitch, fill in with a satin stitch, red.
- **Pockets:** Tiny running stitch, red
- **Sunflower Center & Water Drops:** Straight stitch, red

Block 2 cont'd - My Redwork Garden

BLOCK 2 ASSEMBLY:

Left-Hand Column E

- Following diagram and color photo, complete the Left-Hand Column using Ring Around A Robin, Nine-Patch and Honey Bee Fleur Blocks, adding additional block elements where indicated.

Petal Block Row D

- Following diagram and color photo, sew the 3 appliquéd petal blocks together with sashing.

Lower Right Block Unit B

- Following diagram and color photo, complete Lower Right Block unit using a Nine-Patch and a Ring Around A Robin Block, and adding the additional block elements.

Embroidered Block A

- Following diagram and color photo, complete the Embroidered Block, adding side and bottom borders.
- Join a sashing strip $13\frac{1}{2}'' \times 1\frac{1}{2}''$ to the top of the block.
- Following diagram and color photo, join Block 2 in the alphabetical order given.

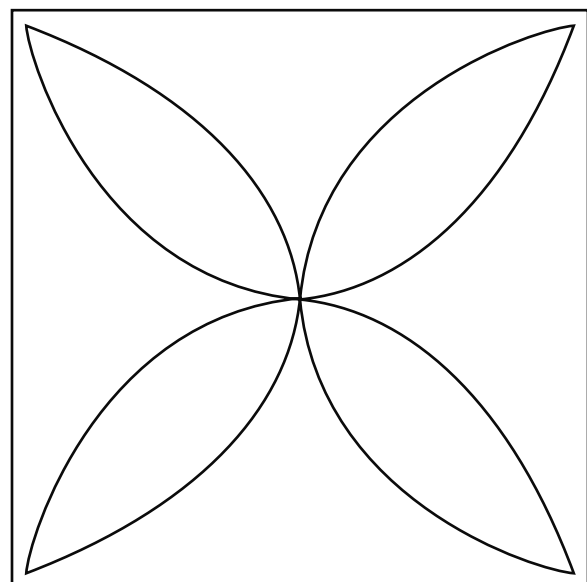
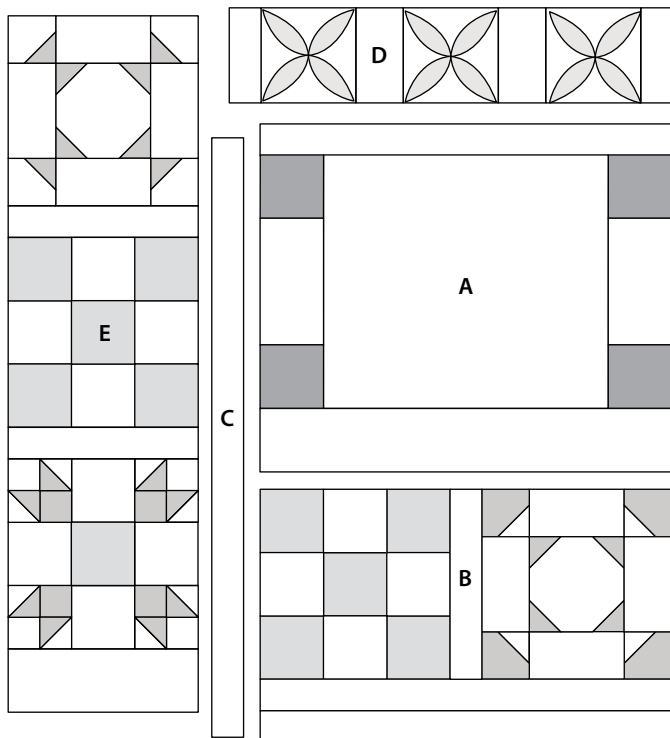
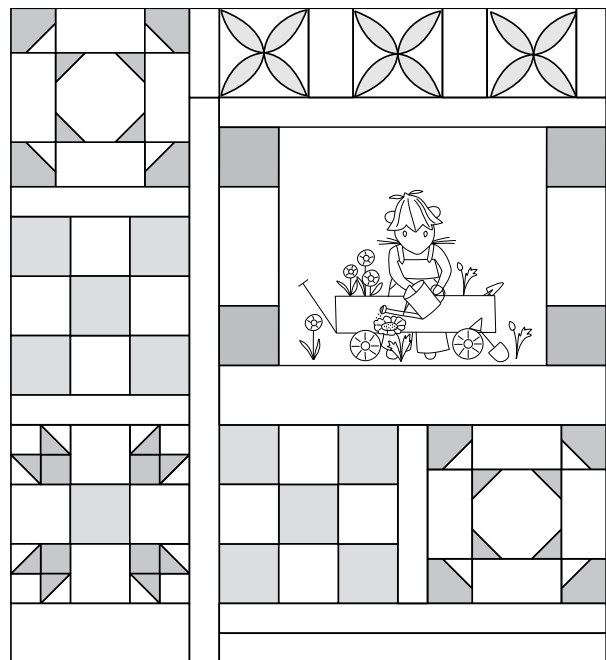

Make three sets of petals

Block 5 - My Redwork Garden

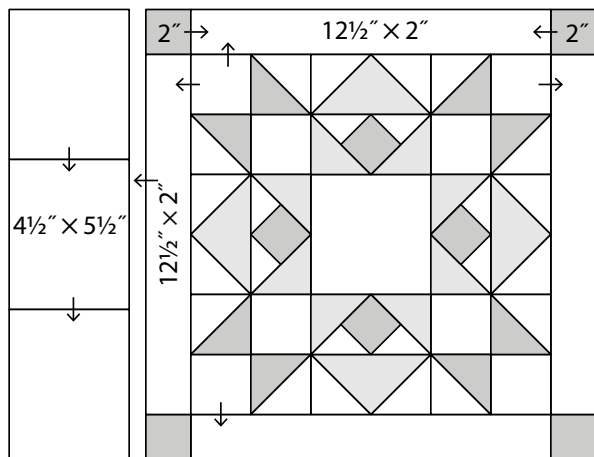

19 1/2" x 15 1/2"

Measurements are unfinished sizes.

Use 1/4" seams. Press in direction of arrows.

Pay attention to the directional print of the fabrics.

All directional fabrics are marked with (*).

Refer to color photo.

BLOCK CUTTING INSTRUCTIONS:

Off-White Bella:

(1) 4 1/2" x 5 1/2" for appliqué background

(4) 2 1/2" x 2 1/2" for Corner Petals

Flirty Fleurs Cream-Red:

(1) 4 1/2" x 5 1/2" for appliqué background

(4) 2 1/2" x 4 1/2" for FG A

Cobblestone Cream-Red:

(1) 4 1/2" x 5 1/2" for appliqué background

Dandelions Cream-Red: (4) 2" x 12 1/2" for border

Berry Dots Red: (4) 2" x 2" for cornerstones

Flirty Fleurs Red: (4) 3 1/4" x 3 1/4" for HSTs

Cobblestone Red: (4) 1 7/8" x 1 7/8" for FG B

Lily Days Cream-Red: (4) 3" x 3" FG B

Early Birds Cream-Red:* (1) 4 1/2" x 4 1/2" for center

Cobblestone Cream:

(4) 3 1/4" x 3 1/4" for HSTs

(12) 2 1/2" x 2 1/2" for Corner Petals, FG A

(4) 2 1/4" x 2 1/4" for FG B

APPLIQUÉ DIRECTIONS:

- Prepare heart appliqué using your favorite method.
- Center hearts on 4 1/2" x 5 1/2" backgrounds. Appliqué.
- Place the hearts and pattern right side up over a light box or table. Trace the outlines. Complete embroidery.

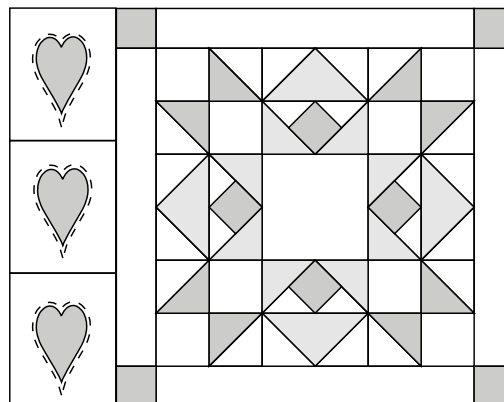

EMBROIDERY: USE 2 STRANDS FLOSS

- **Outline:** Running stitch, red
- Sew the blocks together in a column. Press.

GARDEN STAR BLOCK INSTRUCTIONS:

Half-Square Triangles (HSTs)

- Following diagram and color photo, make (8) 2 1/2" HSTs needed for the corner petals. See Block 3, page 6, for step-by-step instructions about how to make HSTs.

Lily Corner Petals

- Following diagram and color photo, make 4 Lily Corner Petals. See Block 2, Honey Bee Fleur Block, page 9, for instructions about how to make Lily Corner Petals.

Flying Geese (FG) A

- Select a Flirty Fleurs Cream-Red rectangle 2 1/2" x 4 1/2" and 2 Cobblestone Cream 2 1/2" squares.
- Draw a diagonal line across both cream squares.



- Lay a square on one end of the rectangle right sides together as shown, and sew on the drawn line. Trim excess off the corner.



- Repeat on the other end of the rectangle. Press open.
- Make 4 Flying Geese A blocks.

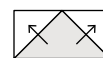

FG A

Flying Geese (FG) B

- Cut 4 Lily Days Cream-Red 3" squares in half diagonally.
- Do the same with 4 Cobblestone Cream 2 1/4" squares.



Block 7 - My Redwork Garden

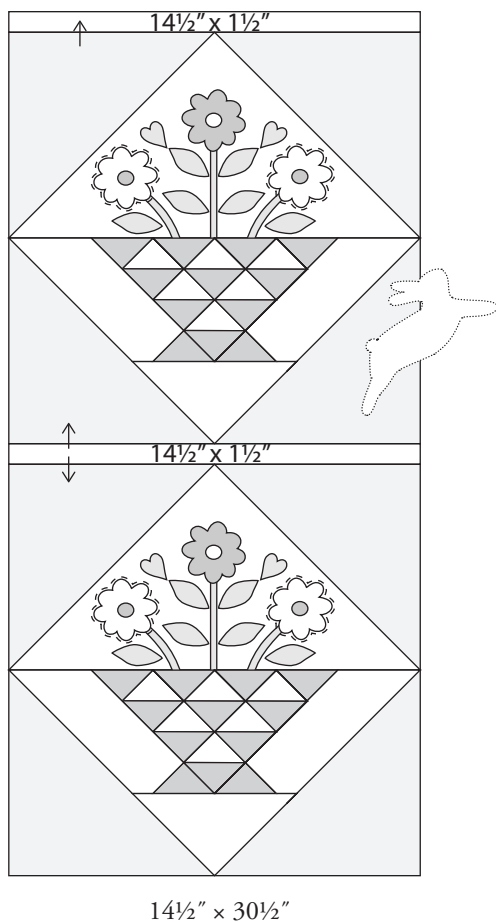

Measurements are unfinished sizes.

Use 1/4" seams. Press in direction of arrows.

Pay attention to the directional print of the fabrics.

All directional fabrics are marked with (*).

Refer to color photo.

GARDEN BASKET BLOCK INSTRUCTIONS:

Half-Square Triangles (HSTs)

- Follow the technique described in Block 1, Buttercup Trio Unit Instructions, page 6, to make HSTs.
- For this block pair 6 Flirty Fleurs Red 3" squares with 3 Cobblestone Cream-Red 3" squares, and 3 Flirty Fleurs Cream-Red 3" squares to make 6 HSTs for each Garden Basket. Trim to 2" square.

Garden Basket Triangles

- Arrange 6 of the same HSTs into a column of 3 and a column of 2. The last HST is its own column. The red corner of each HST must sit in the lower left.
- Sew each column together, adding a 2 3/8" triangle to the top of each column and to the right of the single HST.
- Sew the columns together to make a triangle.
- Sew a 2 1/2" triangle to one end of each of the (2) 2 1/2" x 7 1/2" strips; one should be reversed as shown. Sew 1 strip to each side of the basket.
- Add a 5" background triangle to the bottom of the basket. Trim the top edge of the basket, keeping 1/4" seam allowance beyond the HST points. Make a second Garden Basket.

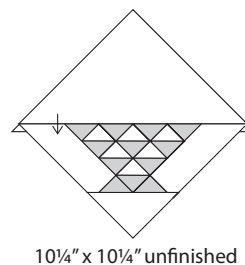
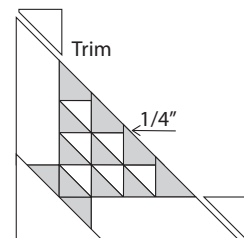
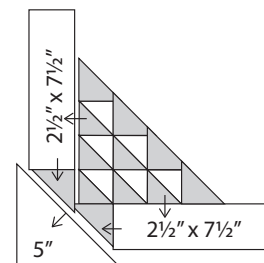
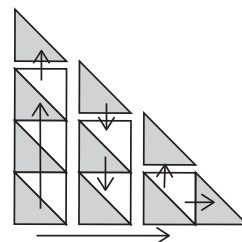

- Sew a 10 1/2" off-white Bella background triangle to the top of one basket block. Press toward basket.. Repeat for second block. The block measures 10 1/4" x 10 1/4", unfinished.

(continued on page 24)

BLOCK CUTTING INSTRUCTIONS:

Garden Basket Triangles

Flirty Fleurs Cream-Red:

- (2) 8" x 8", cut in half once diagonally
- (3) 3" x 3" for HSTs

Cobblestone Cream-Red:

- (2) 8" x 8", cut in half once diagonally
- (3) 3" x 3" for HSTs

Flirty Fleurs Red:

- (4) 2 3/8" x 2 3/8", cut in half once diagonally
- (2) 2 1/2" x 2 1/2", cut in half once diagonally
- (6) 3" x 3" for HSTs

Off-White Bella:

- (4) 2 1/2" x 7 1/2" background sides
- (1) 5" x 5", cut in half once diagonally

Background

Morning Glories Stripe Cream-Red:*

- (2) 14 1/2" x 1 1/2" for sashing

Off-White Bella:

- (1) 10 1/2" x 10 1/2", cut in half once diagonally for appliqué background

Block 7 cont'd - My Redwork Garden

GARDEN BASKET BLOCK INSTRUCTIONS: CONT'D

- Following color photo sew an 8" Flirty Fleurs Cream-Red triangle to opposite sides of basket block. Press toward triangles. Repeat for second block.
- Following color photo sew an 8" Cobblestone Cream-Red triangle to opposite sides of basket block. Press toward triangles. Repeat for second block. The block measures 14½" x 14½", unfinished.
- Join blocks and sashing strips after the applique is complete.

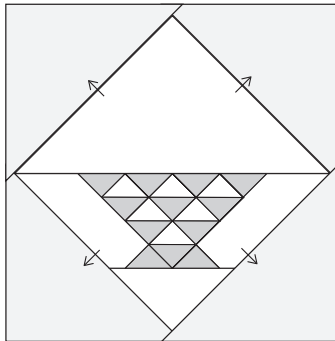

14½" x 14½" unfinished

EMBROIDERY: USE 2 STRANDS FLOSS

- **Outline:** Running stitch, red

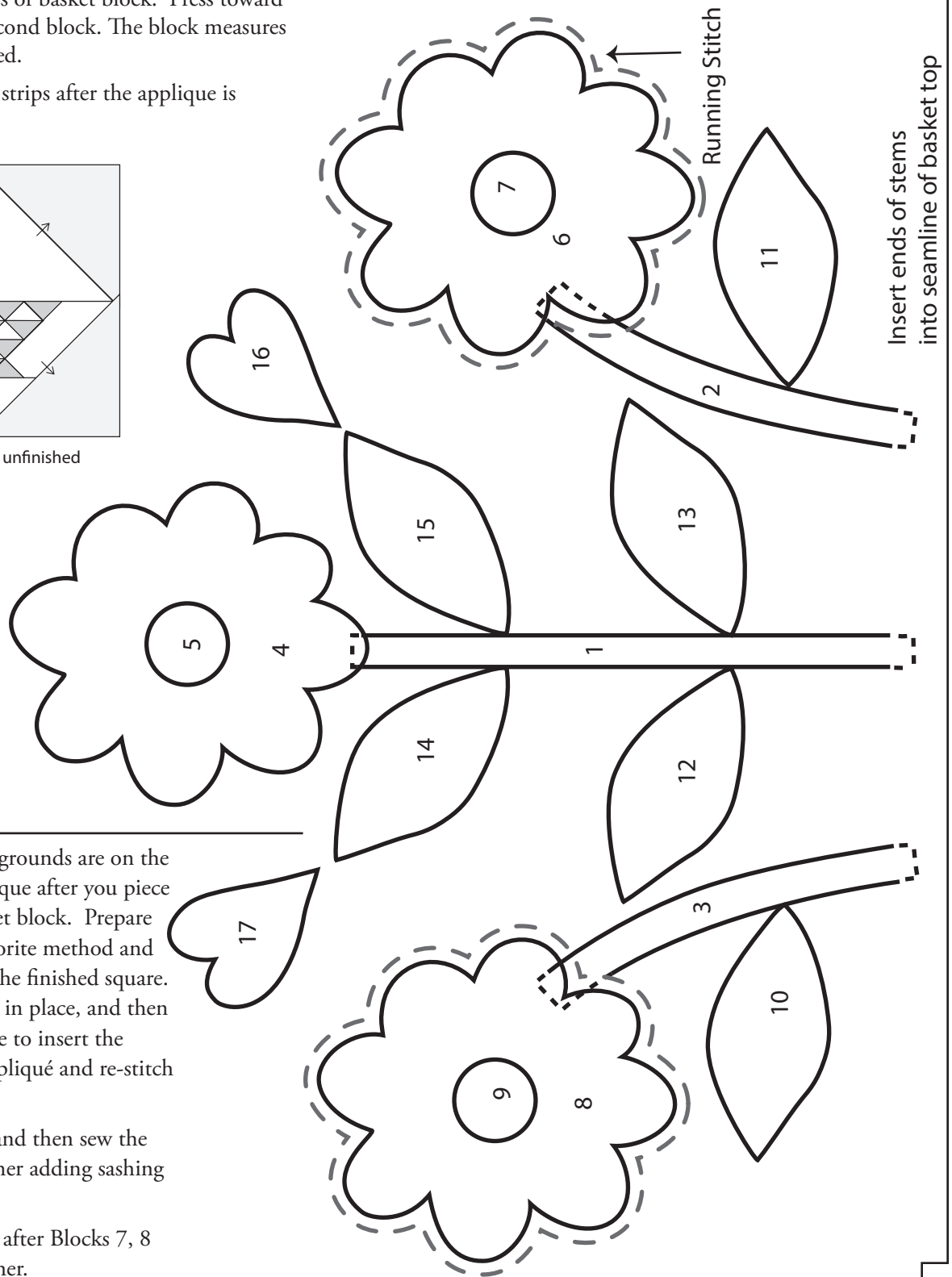

APPLIQUÉ DIRECTIONS:

- Because the flower backgrounds are on the bias, complete the applique after you piece and assemble each basket block. Prepare applique using your favorite method and center the applique on the finished square. Glue-baste the applique in place, and then open the seam allowance to insert the stems. Complete the applique and re-stitch seam allowance.
- Complete embroidery, and then sew the two basket blocks together adding sashing in between blocks.
- The bunny is appliquéd after Blocks 7, 8 and 9 are stitched together.

Block 11 - My Redwork Garden

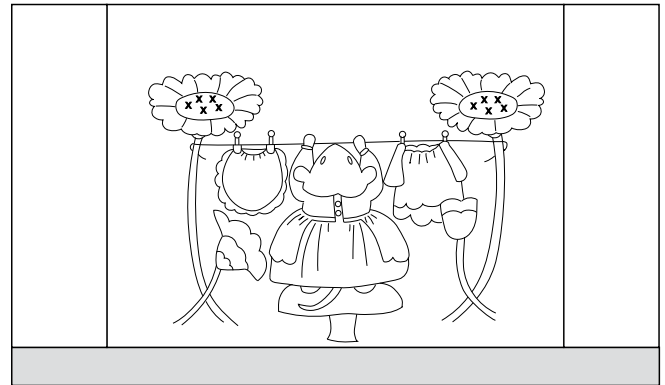
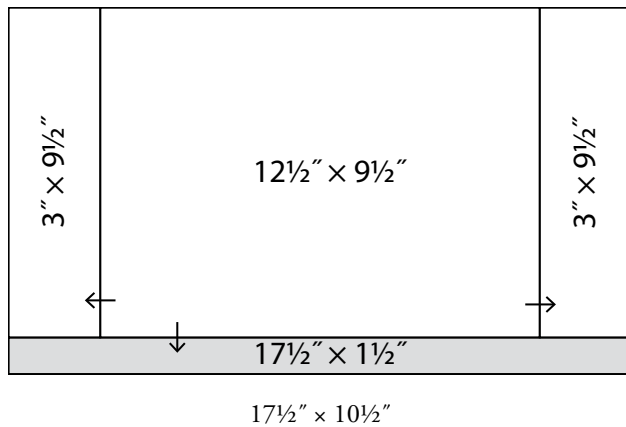

BLOCK CUTTING INSTRUCTIONS:

Dandelions Cream:*

(1) 13" x 10", trimmed to 12½" x 9½" after embroidery

Honey Bee Cream-Red:*

(2) 3" x 9½" for side border

Morning Glories Stripe Cream-Red:*

(1) 17½" x 1½" bottom border

EMBROIDERY BACKGROUND:

- Cut a 13" x 10" background for embroidery. The background is cut oversize and trimmed to 12½" x 9½" after embroidery is complete.
- If you are using the Pellon interfacing, cut a 13" x 10" rectangle. Iron the interfacing to the back of the background following manufacturer's instructions. You'll be able to see through it to trace the drawings.
- Place background over pattern and trace drawing. Complete embroidery and trim block to 12½" x 9½".

Measurements are unfinished sizes.

Use ¼" seams. Press in direction of arrows.

Pay attention to the directional print of the fabrics.

All directional fabrics are marked with (*).

Refer to color photo.

EMBROIDERY: USE 2 STRANDS FLOSS

A tiny stem stitch or backstitch in red is used for all of the embroidery with the exception of the following:

- **Dress Buttons, Clothespin Tops & Mouse Eyes:** Outline with a tiny backstitch, fill in with a satin stitch.
- **Flower Centers:** Cross stitch, red
- **Pockets:** Tiny running stitch, red

ASSEMBLY DIRECTIONS:

- Following diagram and color photo, sew the mouse laundry backgrounds together. Press.